



# INSTALLATION, USE AND MAINTENANCE HANDBOOK

## VALORIANI “BABY”



# ***VALORIANI***



# INSTALLATION, USE AND MAINTENANCE HANDBOOK

## **WARNING**

**DURING THE UTILIZATION SOME SURFACES OF THE FORNOGRILL REACH HIGH TEMPERATURES.**

**BY USING LOW QUALITY COAL , VERY DANGEROUS SPARKLES , FOR THE OPERATOR AND THE ENVIRONMENT, MAY OCCUR**



**BURNS HAZARD**

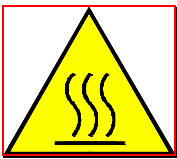

**BURNING SURFACE**



**FIRE HAZARD**

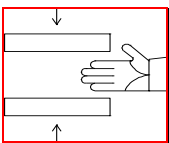

**CRUSHING HAZARD**



**OVERTURING HAZARD**



# INSTALLATION, USE AND MAINTENANCE HANDBOOK

## CONTENTS

- 1.0 INTRODUCTION**
- 2.0 DESCRIPTION**
- 3.0 INSTALLATION SAFETY WARNINGS**
- 4.0 HANDLING**
- 5.0 DIRECTIONS FOR USE**
- 6.0 BAKING TIMES**
- 7.0 CLEANING AND MAINTENANCE**
- 8.0 DIMENSIONS**



# INSTALLATION, USE AND MAINTENANCE HANDBOOK

## GENERAL WARNINGS

- **The present handbook is an integral and substantial part of the BABY OVEN and must be kept available to the operators for any eventual consultation.**
- **Before carrying out any operation, read carefully the information contained in the handbook, with reference to safety , installation, use and maintenance.**
- **The BABY OVEN must be used only for the use for which it has been conceived.**
- **The Manufacturer declines any responsibility for direct and indirect damages caused by a wrong installation , bad maintenance ,infringement, improper use and non-observance of the norms and indications contained in the present handbook.**



# INSTALLATION, USE AND MAINTENANCE HANDBOOK

## 1.0 INTRODUCTION

This handbook contains all the information for the installation, use and maintenance of the BABY OVEN. The original text of this publication , written in Italian language , constitutes a unique reference for the resolution of eventual interpretative disputes bound to the translation in the European languages.

This publication is also to be considered integral part of the BABY OVEN and must be therefore kept for eventual, future references until the final demolition of the BABY OVEN.

### 1.1 Purpose of the handbook

The purpose of this manual is the one to allow the designed people to understand the working of the BABY OVEN, to install and to use it in a safe manner.

For the use and installation the operators shall also follow the specific legislation, related to employment, in force in the country where the BABY OVEN is installed.

### 1.2 Warranty of the producer

The warranty has a duration of 12 months and its course starts from the date indicated in the invoice. The user , in order to benefit of the warranty supplied by the producer , must strictly observe the warnings indicated in this manual.

### 1.3 Warranty terms

In case of verified fault of the handwork, the warranty of the producer is limited to the single free delivery of a new and equivalent component.

**The producer declines any responsibility , direct and indirect, caused by:**

- ✓ Failure to observe the instructions and use different than the one indicated in this manual.
- ✓ Use which does not comply with the specific regulations in force in the country of installation.
- ✓ Changes carried out on the BABY OVEN without authorization.
- ✓ Repairs carried out by unauthorized personnel.

The sale of the BABY OVEN to a second user involves also the delivery of this manual the failure to deliver this manual automatically invalidates the responsibility of the producer with reference to its correct use . In case of sale of the oven to a second user in a country of a different language , it will be responsibility of the primary user to provide for a faithful translation of this manual in the language of the country where the BABY OVEN will be operating.



# INSTALLATION, USE AND MAINTENANCE HANDBOOK

## Company VALORIANI in 1900



## 2.0 DESCRIPTION

### 2.1 Introduction

First of all we wish to thank you for selecting an item from Valoriani.

Our company has manufactured refractory items and PREFABRICATED ovens for over 60 years in our premises located in Reggello, close to Florence. All items produced spring from an idea that Mr. SILVIO VALORIANI had right after World Word II for bread baking.

The concept immediately met the favour of the Italian people and proved to be the winning card of the company. Thanks to their easy assembly, installation and use, these ovens are used to cook many traditional dishes, such as lasagne, roasts, baked pasta, besides of course bread and PIZZA

The special design of the vault in refractory *cotto* perfectly matches the cooking surface made up of elements in REFRACTORY COTTO.

This way our ovens offer the same – or even improved, we may add – features of old wood-fired ovens, which were built with refractory bricks laid down following a special design according to ancient building techniques, whose origins are lost in the mists of time.

*Massimo Valoriani*



# INSTALLATION, USE AND MAINTENANCE HANDBOOK

## 2.2 Intended use

The **BABY OVEN** has been designed for the baking of pizza and products for oven in general. Of course it's possible the baking of other foods complying with the oven cooking type.

The **BABY OVEN** can be used in gardens, terraces etc. All the external components of its structure have been galvanized before being painted with epoxy paint and can support a brief exposure to the rain, but we recommend to repair it in an environment protected by atmospheric agents when not in used, especially during winter season.

The **BABY OVEN** must be fed only with vegetal coal or gas ( in the version with gas burner ) in the quantities and qualities foreseen and recommended.

## 3.0 INSTALLATION AND SAFETY WARNINGS

The **BABY OVEN** has been projected and built with the same features of a professional oven and taking into account the several aspects concerning functionality and safety, in spite of this, in order to fully experience its quality is fundamental to respect a few recommendations:

### 1.1 SAFETY WARNINGS

**3.1.1** When positioning the oven, a minimum safety distance of 3 m from the oven mouth must be respected for inflammable materials, possible sparks from the wood during combustion or expelled from the chimney flue could reach inflammable materials or potential inflammable ones.

**3.1.2** The chimney flue, the oven mouth and the tools used for baking and handling the fire, can reach temperatures dangerous to the touch. Please pay attention during the use, we suggest to use oven gloves.

**3.1.3** The **BABY OVEN VALORIANI** must be installed on an horizontal base of suitable loading capacity or on its optional base.

**3.1.4** In case of installation of the optional wheels on the oven's base, it is possible to move the oven only on plain and perfectly levelled floors, inclined surfaces like stairs or ramps as well as weak surface like lawn, gravel or clay court, may cause the upturning of the oven while moving.



## INSTALLATION, USE AND MAINTENANCE HANDBOOK

**3.1.5** Do not move the oven while there is still fuel inside, neither when it is still hot.

**3.1.6** Pay attention that the oven is not used by children as a toy, this negligence may cause accidents and the movement and climbing on the base or on the dome may cause the upturning of the oven itself with serious consequences.

**3.1.7** The BABY OVEN VALORIANI must be used only by adults or persons who are adequately trained on its proper use and in their right mind.

**3.1.8** During the use and until the oven is completely cold, keep the children at a safe distance from the oven and its tools, possible sparks from wood combustion or very hot surface may cause burns.

**3.1.9.** Do not close for any reason the mouth of the oven when there is flame combustion inside of it, especially when the oven is gas fired, as the combination of temperature and unburned gas may cause an explosion when re-opening the oven mouth.

**3.1.10** When using a wood fired oven, never put inside the oven a quantity of wood over 3 kg, as the flame must develop exclusively inside the oven and never has to reach the metal flue manifold of the flue.

**3.1.11** When using a gas fired oven, regulate the maximum flame so that the flame will develop exclusively inside the oven and never has to reach the metal flue manifold of the flue.

### IMPORTANT

**REFRATTARI VALORIANI DOES NOT TAKE ANY RESPONSIBILITY OF CONTROL  
AND VERIFICATION OF THE OPERATIONS INDICATED IN THIS HANDBOOK**





# INSTALLATION, USE AND MAINTENANCE HANDBOOK

## 4.0 ASSEMBLING AND HANDLING

### 4.1 ASSEMBLING STANDARD BASE

In order to assemble the standard base, follow the scheme below by using the spanners supplied, position the legs inside the octagon and tight efficiently nuts and bolts.

Nr.	Name	Quantity
1	Shelf	1
2	Top octagon	1
4	Standard legs	4
5	Screw - 8 x 16	12
6	Hexagon Nut M8	12

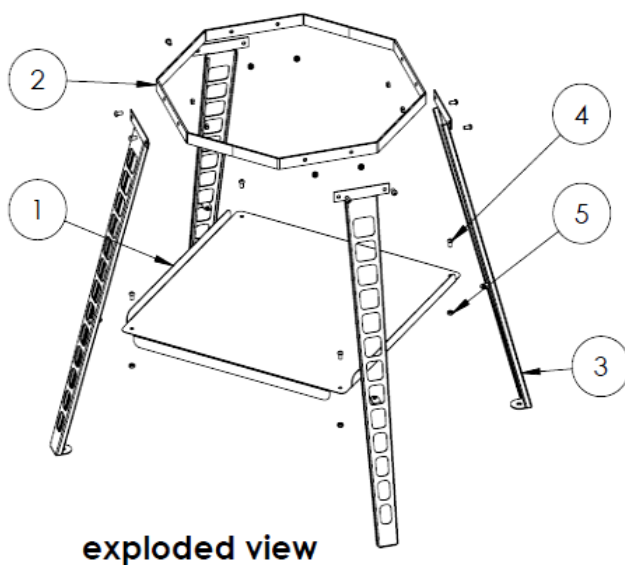

exploded view

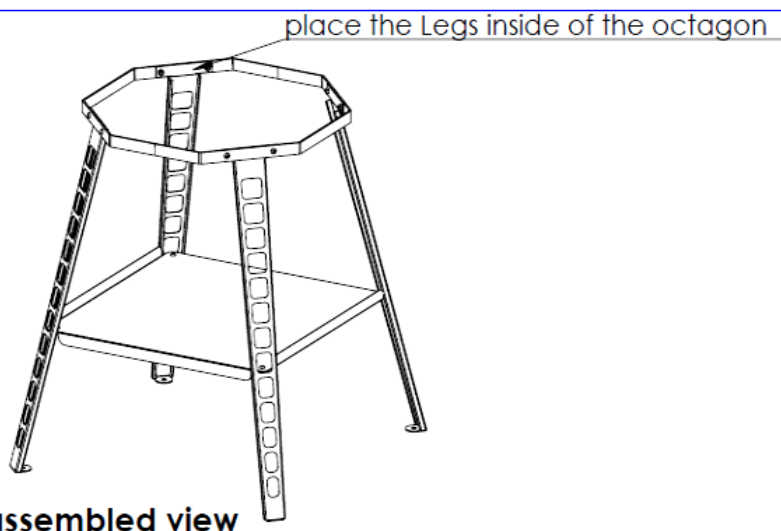

## 4.2. ASSEMBLING LUXURY BASE

In order to assemble the standard base, follow the scheme below by using the spanners supplied, position the legs inside the octagon and tight efficiently nuts and bolts.

ARTICOLO N.	Name	Quantity
1	Luxury Legs	4
2	Shelf 1	1
3	Shelf 2	1
4	Top octagon	1
5	ISO 7380 - M8 x 10 -- - 10N	16
6	Hexagon Nut M8	16

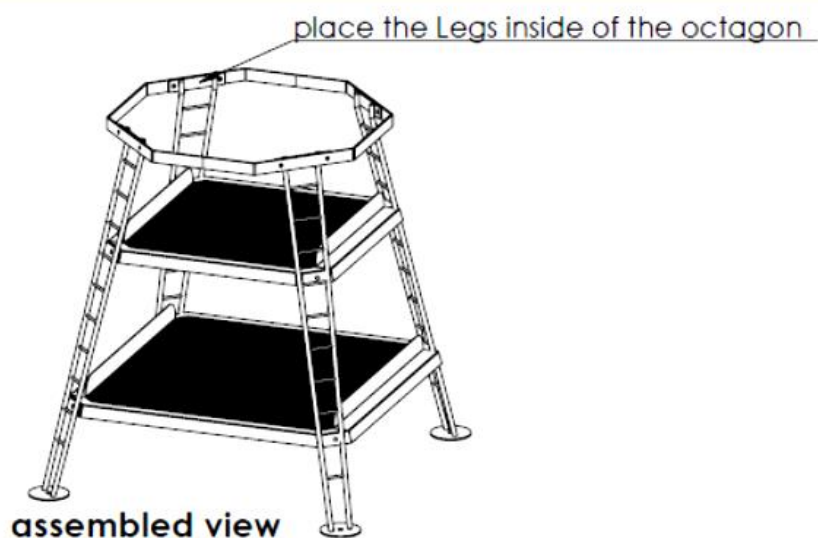
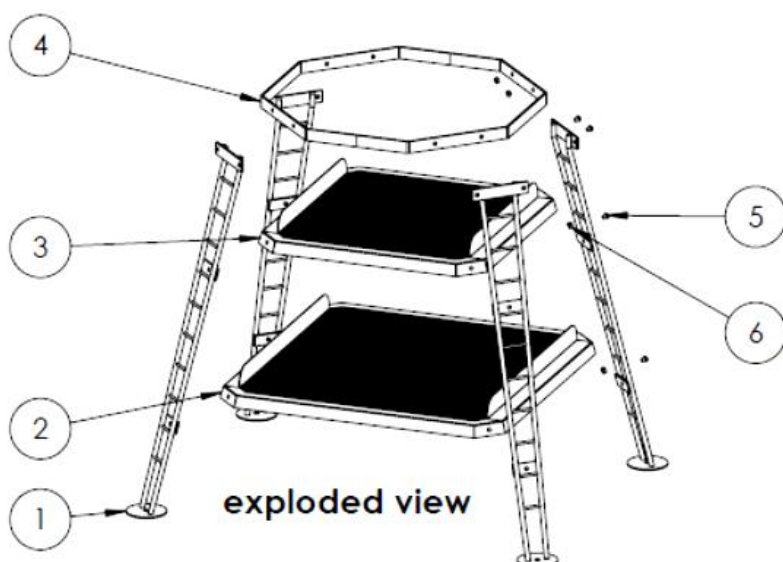

## 4.3 ASSEMBLING OPTIONAL ACCESSORIES

### 4.3.1 Wheels

To assemble wheels under the base, follow the scheme below by using the spanners supplied, tight efficiently nuts and bolts.

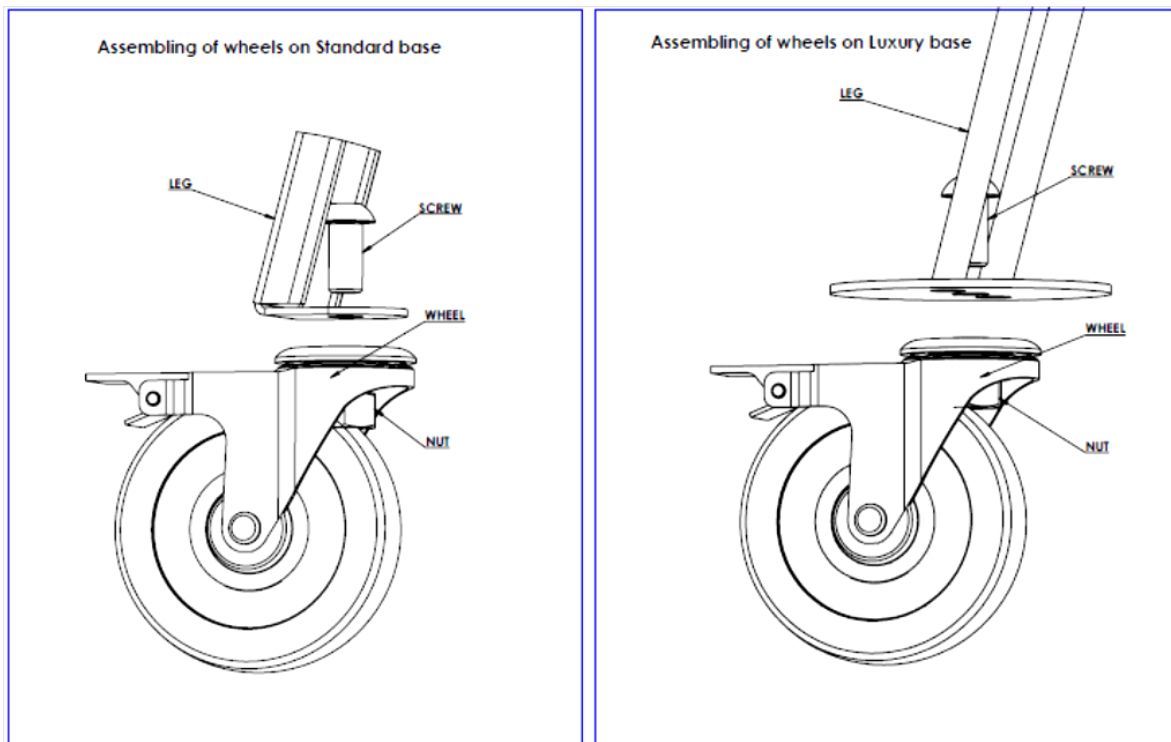

### 4.3.2 Attention:

The **BABY OVEN VALORIANI** must be positioned and used on an horizontal floor of suitable loading capacity. In case of installation of optional wheels, it is possible to move the oven only on plain and perfectly levelled floors, inclined surfaces like stairs or ramps as well as weak surface like lawn, gravel or clay court, may cause the upturning of the oven while moving.

The oven is only placed and wedged on the base, pay attention during possible moves and always move the oven with more persons.

Do not move the oven while there is still fuel inside, neither when it is still hot.



# INSTALLATION, USE AND MAINTENANCE HANDBOOK

## 4.3.3 Shelf

To assemble the shelf, remove the frontal screw of the steel floor, position the shelf and re-insert the screws, level the shelf with the steel floor and tight efficiently the screws.

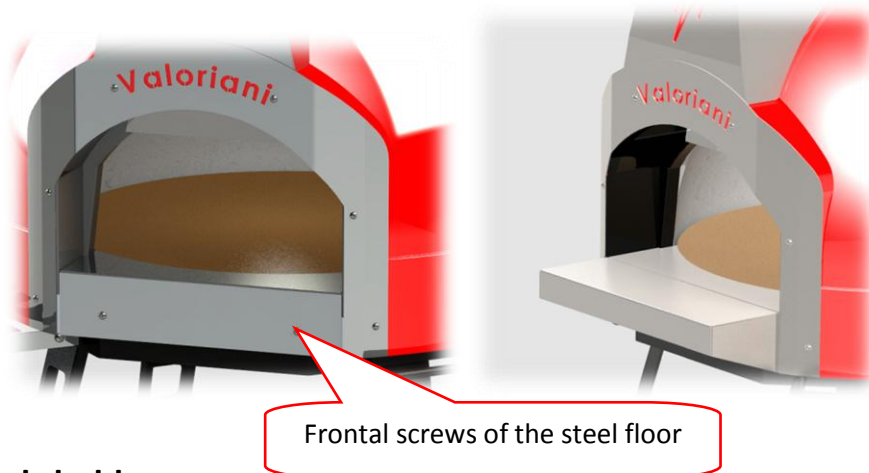

## 4.3.4 Kit Shovels holder

To assemble the shovels holder kit, it is necessary to remove one of the handles to lift the oven, and replace it with the accessory shovels holder shown in the image, re-insert the screws and tight them efficiently.

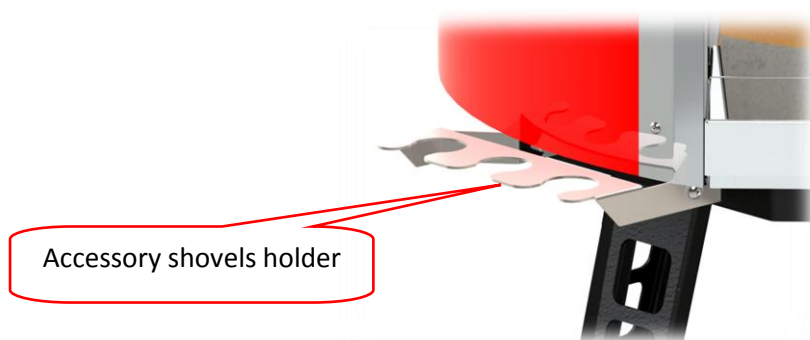

To place the accessory shovels holder it is enough to wedged it in the leg of the base and shown in the images below.

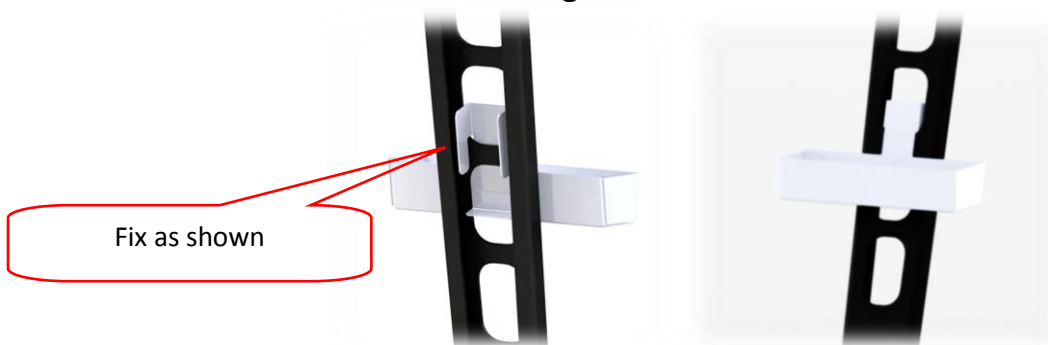



# INSTALLATION, USE AND MAINTENANCE HANDBOOK

## 4.4. POSITIONING THE OVEN ON THE BASE

To place the oven on the base:

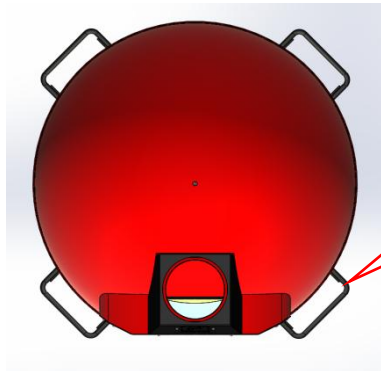

The oven can be lifted up and moved by four people after assembling the relevant lifting handles



The oven can also be lifted up by using the upper eyebolt



Position the oven on its base, by embedding it



# INSTALLATION, USE AND MAINTENANCE HANDBOOK

## 4.5 ASSEMBLING GAS BURNER

4.5.1 Position the gas burner by inserting it from under the oven as shown in the image and block it in position with nuts supplied (see images below)

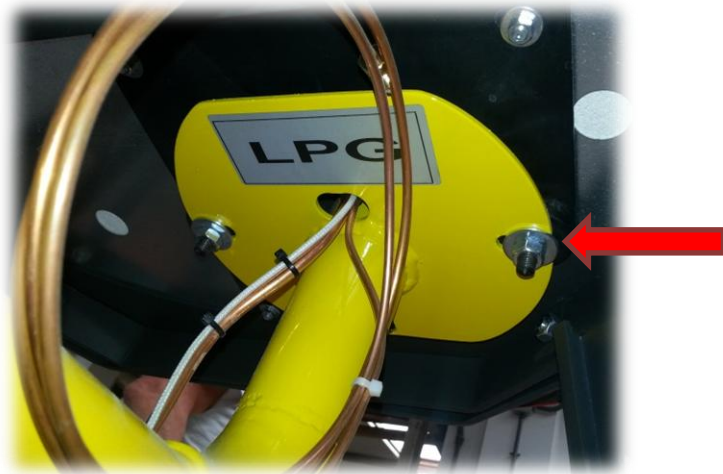
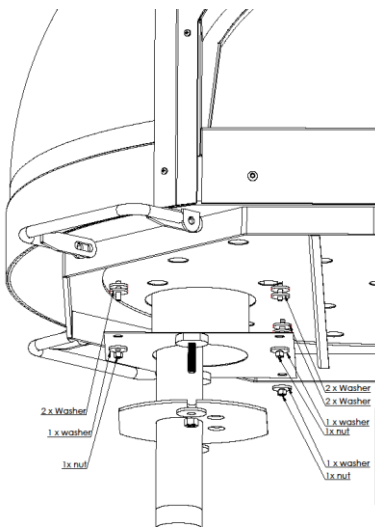

4.5.2 Position the clamp and the gas burner panel with screws supplied (see images below)

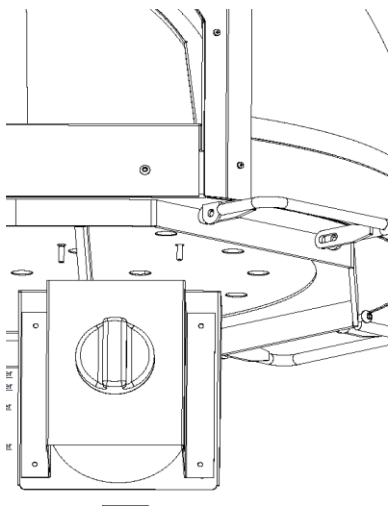

**4.5.3** Position the copper connection of  $\varnothing$  12 mm. Shape and insert it in the gas burner connection and in the control panel connection, tight the fixing joints (see image below)



**4.5.4** Position the copper connection of  $\varnothing$  6 mm. Shape and insert it in the gas burner connection and in the control panel connection, tight the fixing joints (see image below)





## INSTALLATION, USE AND MAINTENANCE HANDBOOK

**4.5.5** Position the connection tube of the thermocouple coming from the gas burner by inserting it in the connection of the control panel and tight the fixing joint, pay attention not to make too tight bends or knots (see images below)

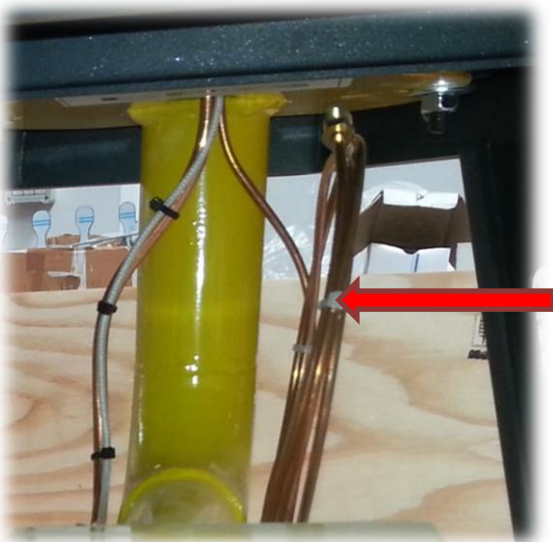

**4.5.6** Connect the lead of the sparkler coming from the control panel to the jack of the gas burner (see images below)

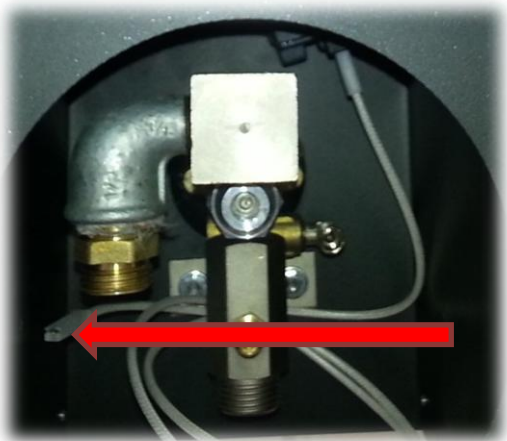





## INSTALLATION, USE AND MAINTENANCE HANDBOOK

4.5.7 Connect the tube of gas supply in the point indicated in the image below (the tube of gas supply is not supplied)

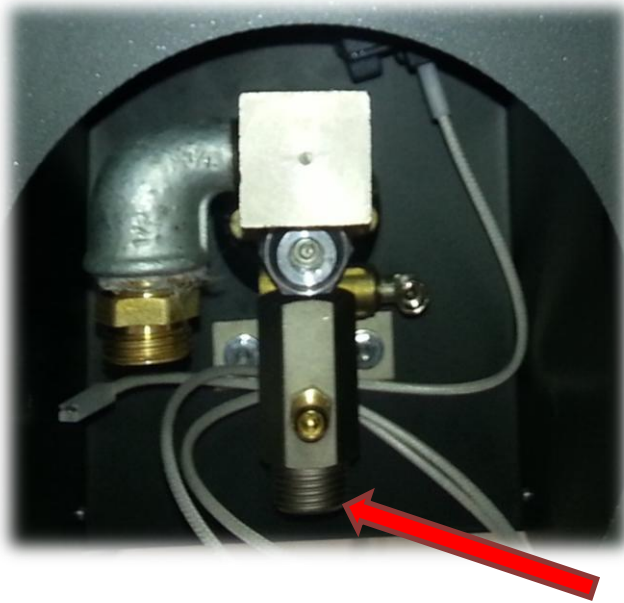

The gas supply can happen through flexible tubes, the gas pressure from a gas bottle needs to be reduced with a pressure reducer, since the gas burner can work with a pressure from 25 and 37 millibar.

To insert the battery for the ignition working, it is enough to unscrew the power button, insert the battery and screw it again.



For further information please refer to the Multilanguage handbook of the gas burner supplied.



# INSTALLATION, USE AND MAINTENANCE HANDBOOK

## 5.0 DIRECTIONS FOR USE

### 5.1 Warnings

- 5.1.1 All the local regulations, included the ones referred to the National Norms, European Norms and International Norms must be observed during the installation.
- 5.1.2 Proceed with firing the oven only after installing the chimney flue
- 5.1.3 Do not use the BABY OVEN as incinerator or in any other way different than the one for which it has been conceived.
- 5.1.4 Do not use different qualities or quantities than the ones suggest
- 5.1.5 Do not use liquid fuels
- 5.1.6 The OVEN, in particular its outside surfaces , when it's in operation, it reaches high temperatures to the touch, handle with care to avoid burnings.
- 5.1.7 Do not carry out any not authorized changes
- 5.1.8 Use only original spare parts recommended by the producer.
- 5.1.9 When using a wood fired oven, never put inside the oven a quantity of wood over 3 kg, as the flame must develop exclusively inside the oven and never has to reach the metal flue manifold of the flue.
- 5.1.10 When using a gas fired oven, regulate the maximum flame so that the flame will develop exclusively inside the oven and never has to reach the metal flue manifold of the flue.

### IMPORTANT

DO NOT KEEP IN THE HEAT RADIATING AREA OR IN FIRE HAZARD AREAS, FLAMMABLE MATERIALS OR POTENTIALLY LIKE THAT. OBSERVE ALL THE NORMS IN FORCE IN THIS MATTER IN ORDER TO STOCK CORRECTLY THE OVEN'S FUEL

### IMPORTANT

LITTLE AND EVENTUAL CRACKS INSIDE THE CROWN'S ELEMENTS ARE PERFECTLY NORMAL AND ARE DUE TO THE THERMAL EXPANSION OF THESE ONES TO HIGH TEMPERATURES . SUCH CRACKS DO NOT COMPROMISE IN ANY WAY THE WORKING OF THE OVEN, THEY ARE SYMPTOMS OF A DEHUMIDIFICATION OF THE HANDWORK.



# INSTALLATION, USE AND MAINTENANCE HANDBOOK

## **IMPORTANT**

IN CASE OF AN EXTENDED INACTIVITY OF THE BABY OVEN, PROCEED WITH A SLOW RELIGHTING

## **IMPORTANT**

WE RECOMMEND TO FOLLOW CAREFULLY WHAT ABOVE INDICATED, SINCE THE ALMOST TOTALITY OF THE CRACKS ON THE CROWN'S ELEMENTS OCCUR DUE TO A TOO FAST DRYING.

## **5.2 FIRING OF THE WOOD FIRED OVEN**

When the oven is new, it contains a quantity of residual moisture, which during the drying must not turn into steam inside the handwork. THEREFORE IT'S FUNDAMENTAL to start very carefully with the first firing in order to avoid the above mentioned effect, which could create cracks to the handwork.

For THE FIRST FIRING, which has to be carried out gradually and constantly for 3 days days, you MUST proceed as follows:

- 5.2.1 Light a little fire in the central part of the oven, with a few light wood.
- 5.2.2 Keep an even inside temperature to about 100/150 C° CONSTANTLY for the first day.
- 5.2.3 From the second day raise the temperature of 50 C° each 4 hours, when the dome will start whitening, then the first baking tests can be made.
- 5.2.4 When using a wood fired oven, never put inside the oven a quantity of wood over 3 kg, as the flame must develop exclusively inside the oven and never has to reach the metal flue manifold of the flue.
- 5.2.5 For a proper heating of the oven, after starting the fire we suggest to use small wood logs of maximum length 20 cm and diameter 4 cm.
- 5.2.6 We discourage the use of both resinous wood (pine – fir), as that would give a not suitable aroma, and poplar or birch wood because of their high level of unburst particles.



# INSTALLATION, USE AND MAINTENANCE HANDBOOK

## 5.3 FIRING OF THE GAS FIRED OVEN

### 5.3.1 GAS BURNER REGULATION

- a) In order to fire the pilot flame, you must press the handle and turn it counter clockwise to the position N. 1 (star), keep the handle pressed (which allows the exit of the gas to the pilot) together with the power button that creates sparkles to fire the pilot flame (see image below)



- b) The first firing can be hard when it takes time before the air contained in the  $\varnothing 6$  copper tube, which supply the pilot, completely goes away. It is necessary to insist until on the top of the pilot flame all of the 3 flames are on, in order to get a proper ignition of the main burner (see image below).



## INSTALLATION, USE AND MAINTENANCE HANDBOOK



- c) Press and turn counter clockwise the handle, and place it in position high flame N. 2 (see image below)



- d) Extract the handle and regulate the height of the flame by acting on the screw (see images below). The right range is when the flame slightly overstep the centre of the oven's dome. By turning it clockwise the gas power decreases, by turning it counter clockwise the gas power increases.



## INSTALLATION, USE AND MAINTENANCE HANDBOOK



- e) Press and turn counter clockwise the handle, and place it on low flame (see image)



- f) Extract the handle and regulate the high of the flame by acting on the screw (see images below). The right range is when the low flame length is about the half if compared to the long flame length. By turning it clockwise the gas power decreases, by turning it counter clockwise the gas power increases. *(In any case when in low flame, the oven must not increase the temperature but maintain it)*



# INSTALLATION, USE AND MAINTENANCE HANDBOOK



- g) Insert again the handle. The low and high flame are now regulated, and with the handle it is possible to modify the heat requirements on the basis of what you are going to cook.
- h) To turn off the flame of the main gas burner and leaving turned on just the pilot flame, you need to place the handle on the star (see image below)





## INSTALLATION, USE AND MAINTENANCE HANDBOOK

- i) To turn completely off the main gas burner and the pilot flame, you need to place the handle on the black dot (see image below).



- j) The flame needs to be smooth and silent of yellow colour, but it does not need to colour too much the oven's dome. The air shutter opening regulation can change on the basis of the gas mix used, it usually needs to be placed on the reference N.3 or N.4 (see image below)

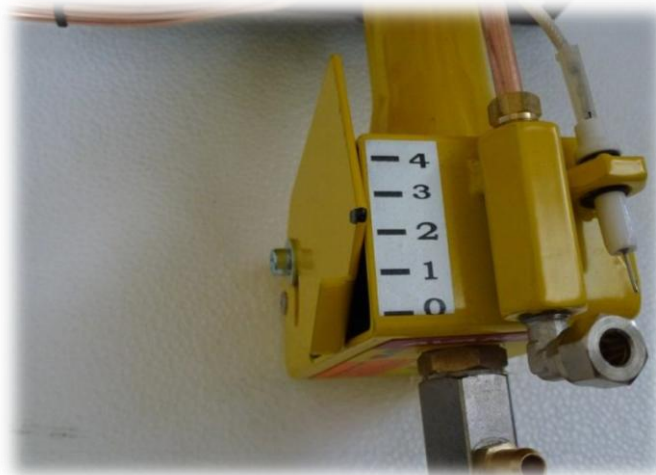

- k) If a small gas tank is used, likely it won't be possible to use all the gas that it contains because of the temperature reduction that happens during the gas transition from liquid to gaseous state inside the tank. This event happens especially with small gas tanks. Should this inconvenient happen, we suggest to replace the "frozen" tank with a room temperature tank. The frozen tank can be used till its complete emptying when back to room temperature.





# INSTALLATION, USE AND MAINTENANCE HANDBOOK

## 5.4 Use of smoke detector

The smoke detector can be used in two different positions, in order to reach two different outcomes.

The INTERNAL position lowers the height of the oven's mouth, thus allowing a smaller heat dispersion and a bigger superior thermic reflection.

Deflector fixed in  
internal position with  
nuts and wings





# INSTALLATION, USE AND MAINTENANCE HANDBOOK

The OUTER position lowers the height of the oven's entrance, thus allowing a major combustion smokes extraction but as a consequence also a bigger heat dispersion and a smaller superior thermic reflection.

Deflector in outer position fixed with nuts and wings



## 6.0 COOKING TIMES

The cooking times are highly variable, and are due, in addition to the type of product, the internal temperature. One of the most important prerogatives of the oven, is precisely the 'UNIFORMITY' of cooking in every working condition and temperature of use.

## 6.0 CLEANING AND MAINTENANCE

### 7.1 Cleaning

To clean the inside of the oven, it is recommended to only use special brushes made of brass available in the tools set (optional accessory). The outside cleaning, can be done only when the oven is cold buy using a soft cloth and not aggressive cleaning products.

### 7.2 Maintenance



# INSTALLATION, USE AND MAINTENANCE HANDBOOK

Standard maintenance refers just to the overall cleaning of the oven. For gas burner maintenance refer to qualified personnel. Each extraordinary maintenance operation must be carried out by qualified personnel.

## 8.0 DIMENSIONS

PROBLEM	CAUSE
<b>the BABY OVEN does not heat properly</b>	- Insufficient fuel or not suitable (ex. wet coal or wood or not dried enough) -Insufficient flow or pressure of the supplying gas ( in case of gas version )



# INSTALLATION, USE AND MAINTENANCE HANDBOOK

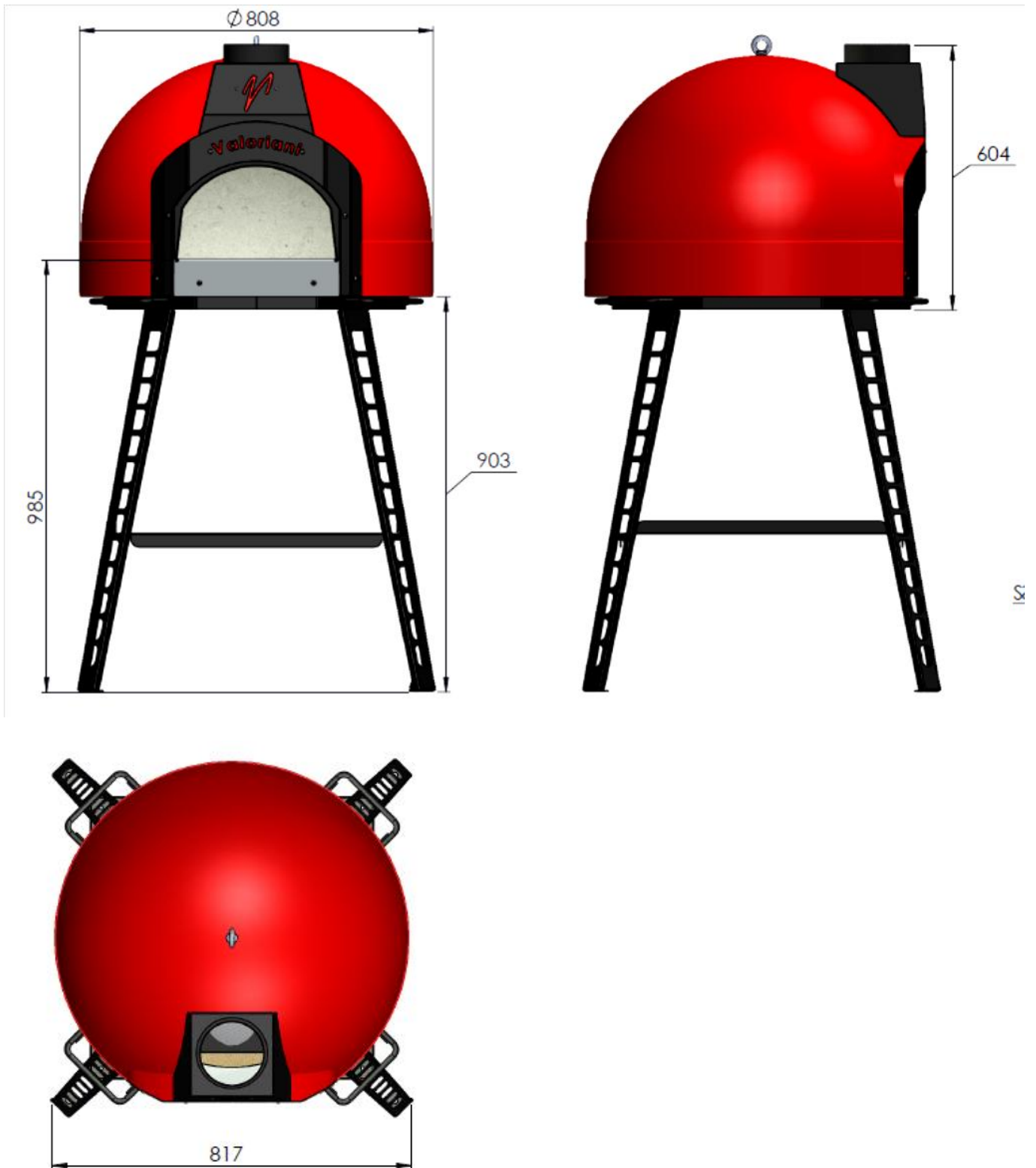



## INSTALLATION, USE AND MAINTENANCE HANDBOOK

IT IS NOTED THAT EVENTUAL BUILDING WORKS AND CONSTRUCTION WORKS IN GENERAL , SHOULD BE EVENTUALLY CARRIED OUT BY THE CUSTOMER AND AT HIS CHARGES , UNDER HIS FULL AND EXCLUSIVE RESPONSIBILITY , BY AN ADMINISTRATIVE , CIVIL AND PENAL ASPECT . THE CLIENTS UNDERTAKES AND WARRANTS STARTING FROM NOW TO DETECT REFRATTARI VALORIANI S.R.L FREE FROM ANY AND ALL NEGATIVE CONSEQUENCES SHOULD ARISE TO THIS ONE AND CAUSED BY EVENTUAL ADMINISTRATIVE , URBAN PLANNING AND PENAL BREACHES , BY WARRANTING TO FACE ALL THE EVENTUAL EXPENSES, PENALTIES INCURRED AS A RESULT TO THE BREACHES COMMITTED BY THE CUSTOMER.



# INSTALLATION, USE AND MAINTENANCE HANDBOOK

Sede legale, amministrazione e stabilimento: Via Caselli alla Fornace, 213 – 50066 REGGELLO (Firenze)  
Tel.: +39/055-86.80.69 (r.a.) Fax: +39/05586.95.992 Web: [www.valoriani.it](http://www.valoriani.it) E-mail: [valoriani@valoriani.it](mailto:valoriani@valoriani.it)